

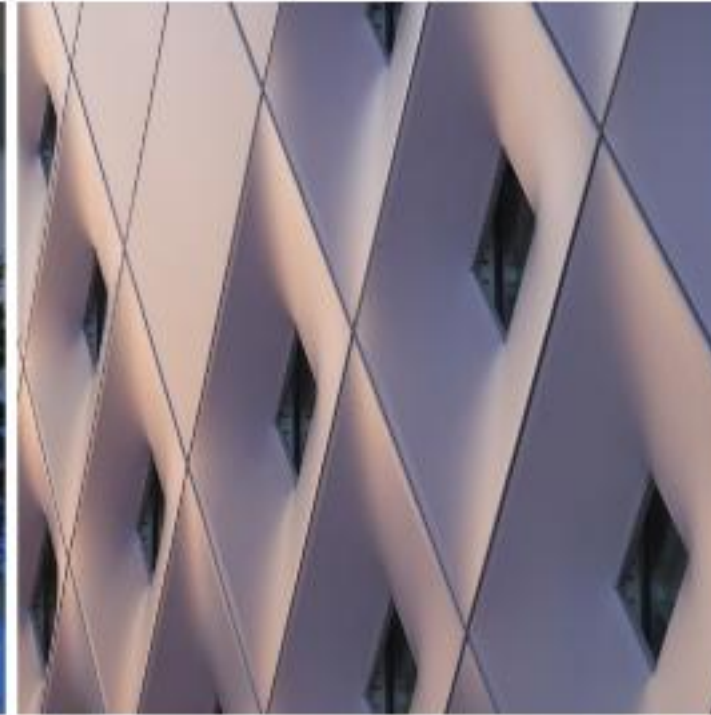

Telephone: +44 (0)117 971 2229
Email: kevinh@basestructures.com

TEXO® by Tensoforma



TEXO® is a revolutionary panel system which opens up the potential for the latest architectural fabrics to be easily incorporated into mainstream construction.

The unique patented panel system holds the fabric constantly in pre-tension, whatever the environment, this results in an extremely lightweight, permanent and versatile cladding solution that's a highly cost effective alternative to traditional materials such as steel or glass.



TEXO[®] – aesthetic potential

TEXO[®] was used to achieve the aesthetic vision for the Shanghai World Expo 2010 UBPA pavilion B3-2. The brief stipulated an uninterrupted rectangular space 78m x 28m, however the architect wanted to avoid the prospect of an uninteresting 'box'.

A TEXO[®] envelope with translucent Silicone glass fabric and curved surfaces created a natural 'soft box' effect. The TEXO[®] panel was adapted to incorporate an inner frame which created 3 dimensional surrounds for the windows which are set back within the facade.



TEXO® – solar control

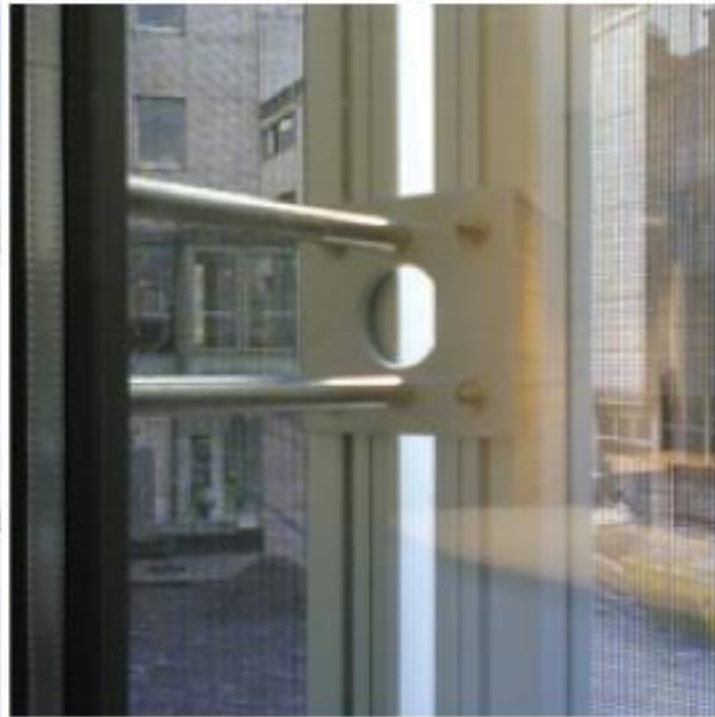

Effective Brise Soleil shading solutions are increasingly important in keeping building energy consumption to a minimum.

Deichmann stores used TEXO® panels to over clad an existing glass façade and reduced the internal energy consumption of the store by over 40%, massively reducing internal solar gain and glare.

The TEXO® panels are extremely lightweight and could be fixed directly to the existing curtain walling system, removing the requirement for a further costly support structure.

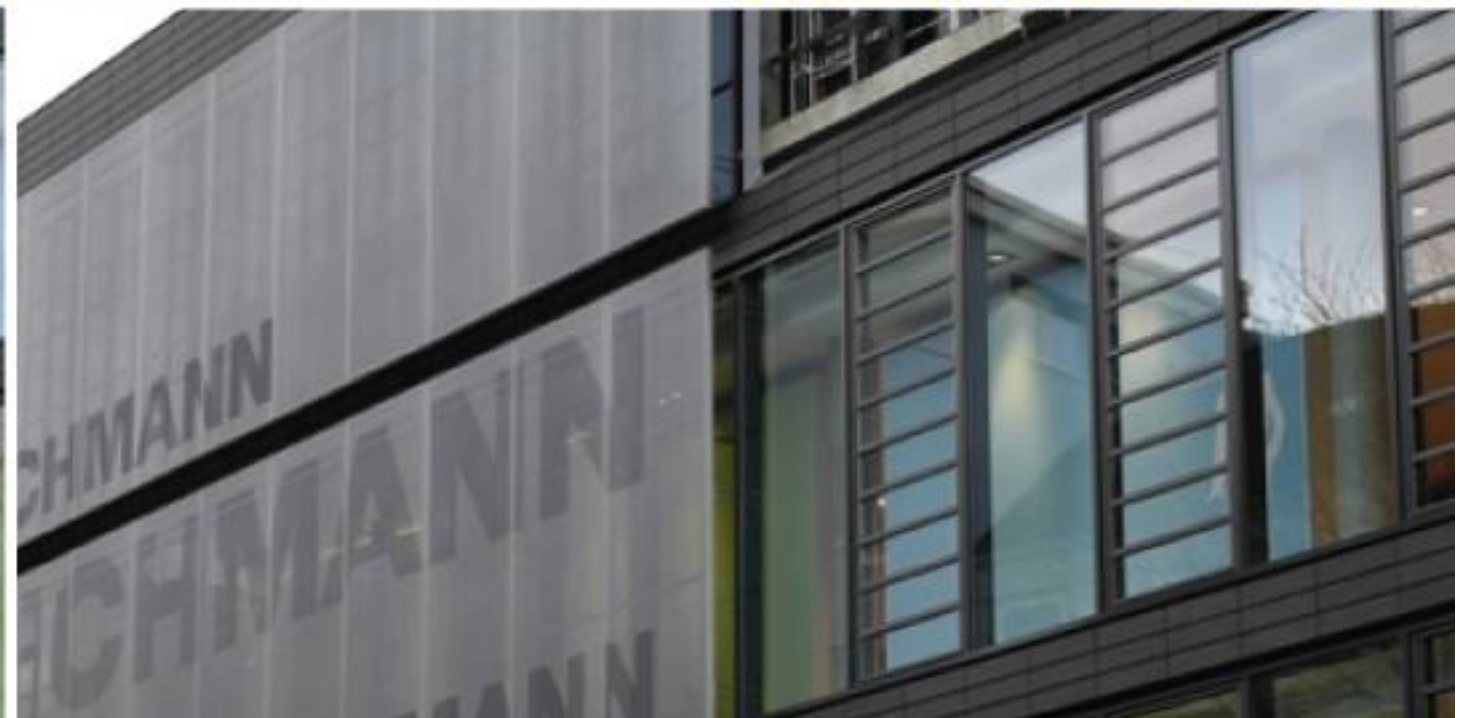



Telephone: +44 (0)117 971 2229
Email: kevinh@basestructures.com

TEXO® – stadia refurbishment



A lightweight solution is paramount if attaching the cladding to an existing structure as in the case of the refurbishment of old stadia structures like Rostock Stadium, and the Football Stadium in Gijon, Asturias, Spain.

The TEXO® panel is incredibly light, for example when the Rostock Football Stadium in Germany was over clad by TEXO® each 220cm x 840cm panel weighed only 70kg and was installed by a small team in only 20 minutes.

The TEXO® system created a branded external façade while still allowing light into the internal space under the stands enabling it to be used in all weathers.



TEXO® – commercial rejuvenation



A TEXO® solution can transform a building and prevent the need for demolition and reconstruction.

The aesthetic of a basic commercial building can be completely rejuvenated using TEXO® panels as seen here in the Italmoda and Coni projects. The TEXO® veil also improved the overall energy performance and internal environment of the buildings.



TEXO® – speed



Planning sensitive design and speed of construction are often a requirement.

No less for Sainsbury's supermarkets who needed to quickly build a multi-storey car park in an urban area subject to strict planning specification.

Working with Unit Architects and Condek the TEXO® system helped to solve these complex issues.

The solution: TEXO® panels carrying a printed mesh fabric with 2000m² installed in only 15 days.

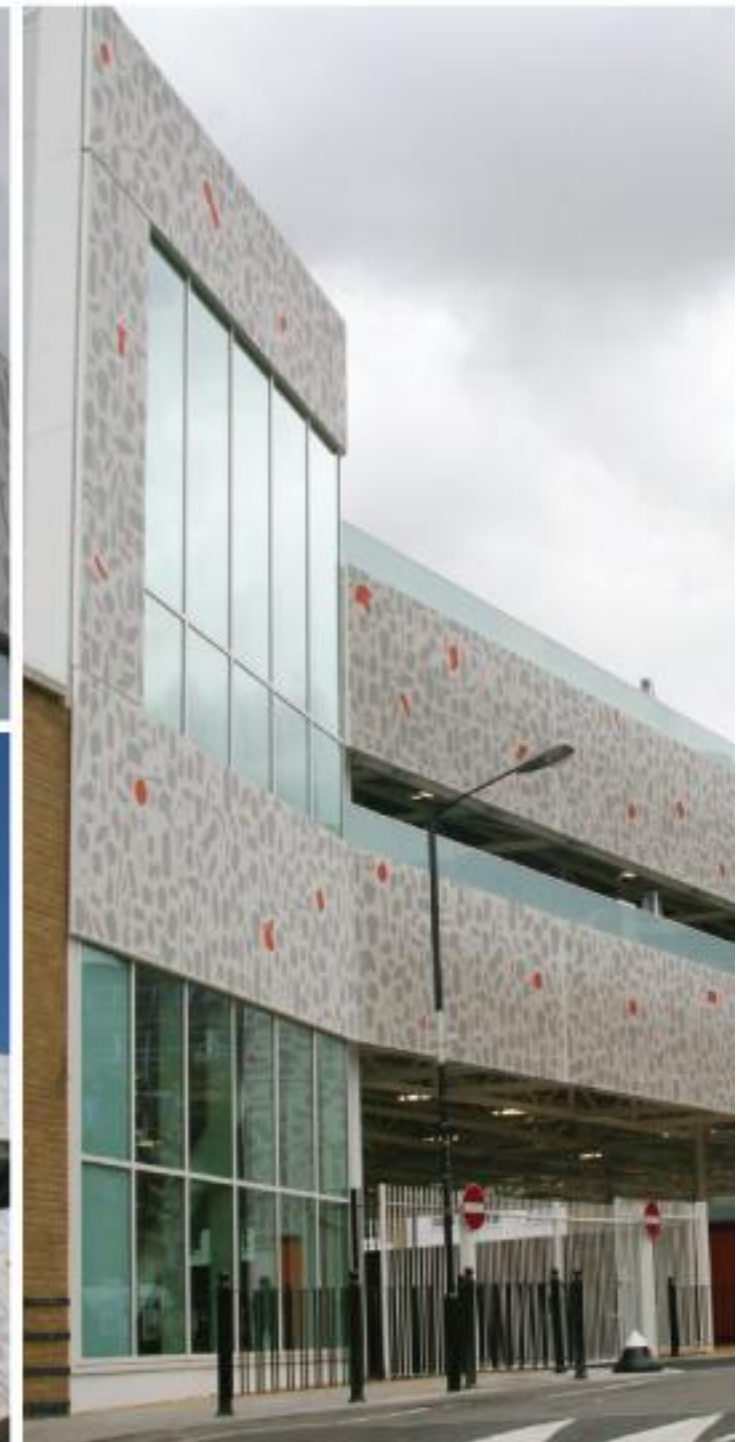
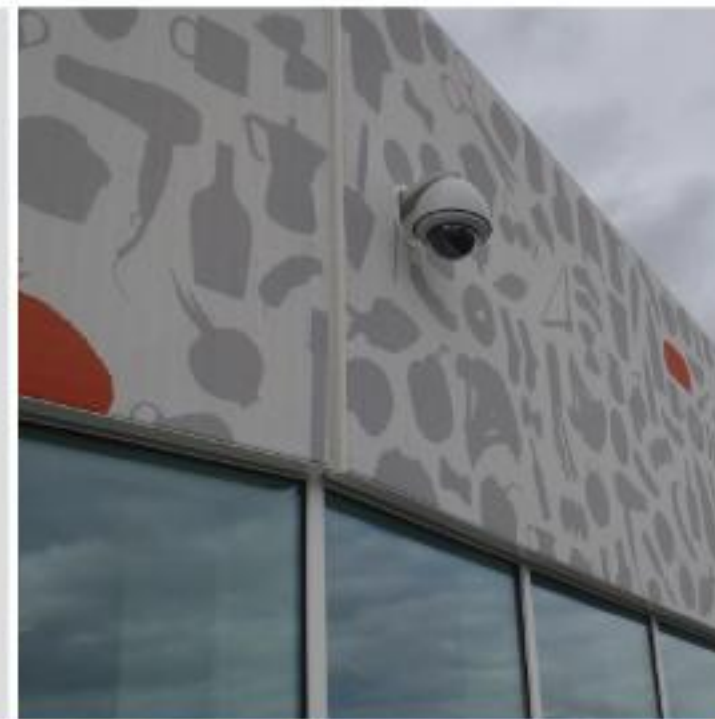

TEXO[®] – roofing

In a project by Base Structures in the UK TEXO[®] has been used to create a roof and is now proven as a viable, lightweight alternative to glass.

The Nottingham University Samworth Academy used TEXO[®] as an alternative to a 900m² glass roof. Single skin, clear ETFE TEXO[®] panels were used over an unheated internal street. As well as providing a shelter, it was imperative that the roof allowed a high level of natural light to enter the street as it was going to be bordered by classrooms.



This was the first time that TEXO[®] had been adapted as an alternative to a glazed roof.

The solution offered a high degree of prefabrication and featured very low weight components which greatly reduced the risk of damage and injury on site.

TEXO[®] delivered a highly innovative solution that matched the aesthetic requirements with a robust build quality, offering a +30-year lifespan, all installed swiftly and cost-effectively, meeting the brief and budget.

The architect was particularly delighted with the high light levels the TEXO[®] solution achieved. The ETFE was virtually indistinguishable from conventional glazing (97% translucency).

The TEXO[®] option proved almost 40% cheaper than glass and less than 1/10th the weight of glass, including the TEXO[®] frame structure.

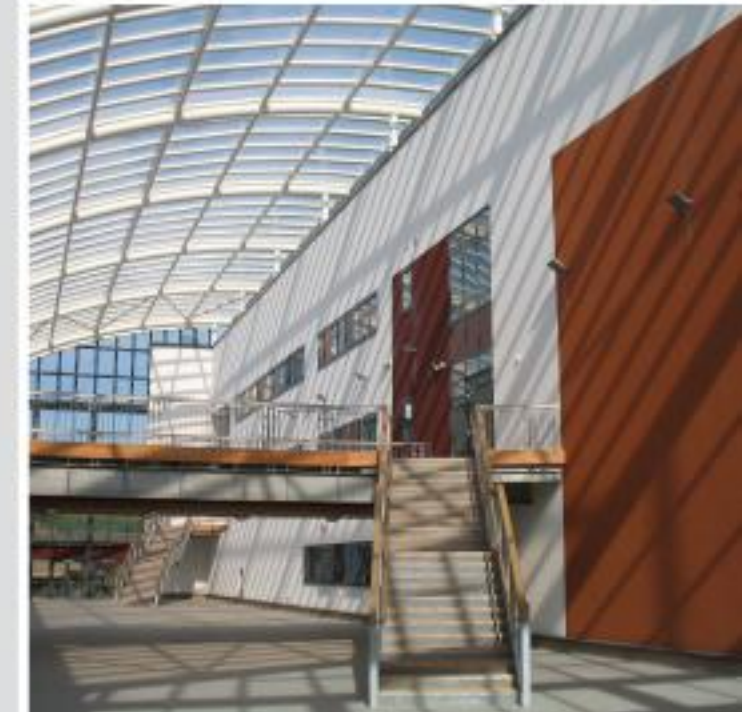



Telephone: +44 (0)117 971 2229
Email: kevinh@basestructures.com

TEXO® – residential



Applications for TEXO® are almost endless and extend to residential buildings too.

Houses built in Vienna, Austria and Postdam, Germany used TEXO® panels on sliding track systems which allowed them to be moved to change the light and shade within the building according to the position of the sun.

The option to automate these types of designs is evolving, and opening up new ways of using TEXO® for control of shading, solar gain, and glare.

TEXO® – technical

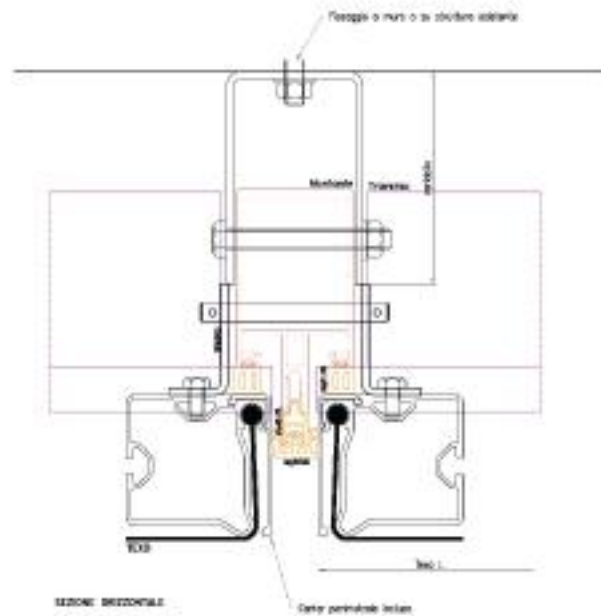

The finished TEXO® product is a panel but can be more accurately described as a complete system comprising physical properties, design and a proprietary manufacturing process.

Architectural fabric is attached to an extruded aluminium frame by an elastomeric strip edge detail in a manufacturing process which uses a specialist tensioning system to set correct biaxial tension of the fabric according to the properties of the fabric and the environmental requirements of the building.

The strip then acts like a spring which absorbs loads and then returns the fabric to the original pre-tensioned position and, as a result, massively reduces the loads transmitted to the primary structure compared to traditional tensile fabric engineering principals. Allowing TEXO® panels to easily be integrated into standard curtain walling systems and other cladding fixing methods as shown in these images.

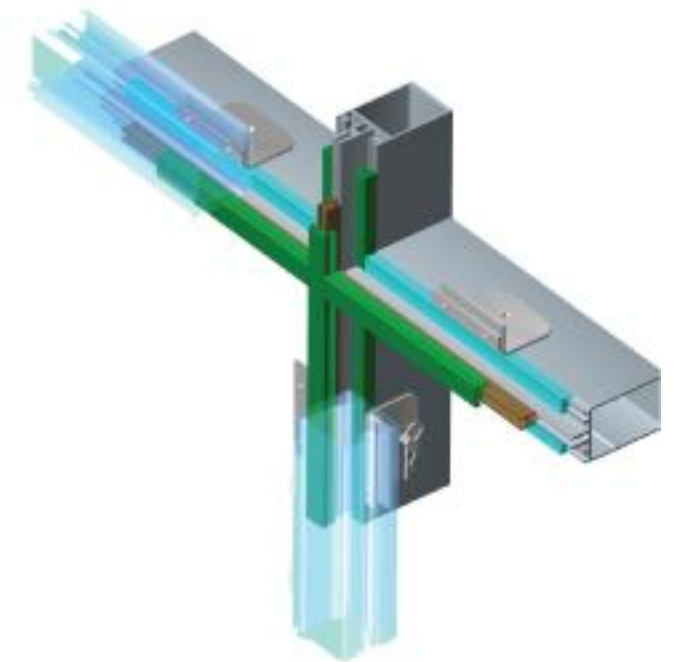
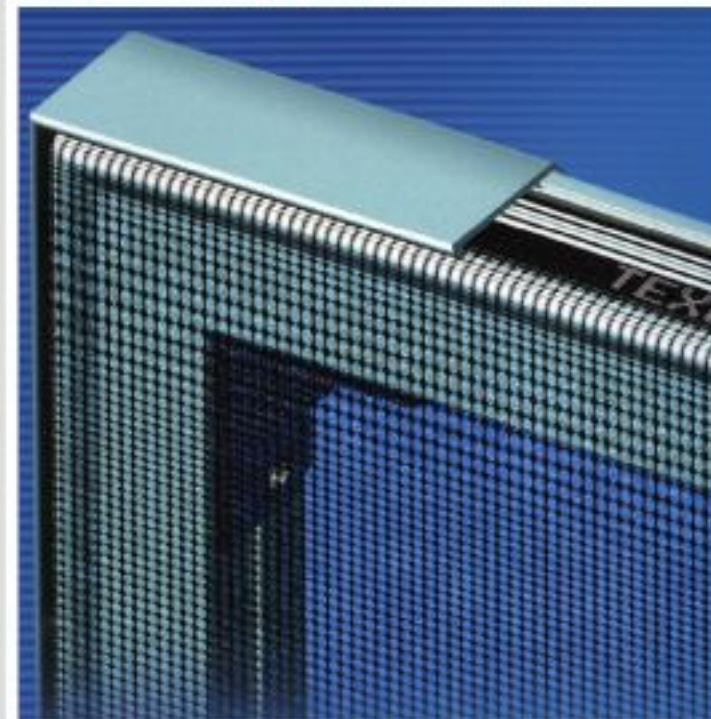
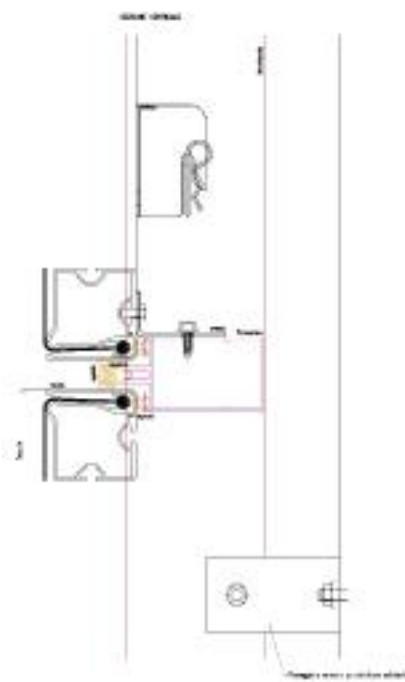



TEXO® – evolution

Continued evolution of the system has added different extrusions:

- TEXO® 60 used for all projects above
- TEXO® 55 which can carry a double fabric skin resulting in a panel with acoustic or thermal properties
- TEXO® 100 designed to create a “light box panel” reducing shadows caused by the frame; as seen in the unique Prada façade opposite.

Continued liaison with technical fabric manufacturers (external and internal), and different printing processes, creates an ultimately flexible cladding panel, proven to deliver practical and aesthetic challenges which couldn't be met by any other construction material.

TEXO® has also been very successfully used for a multitude of internal projects such as ceiling and partitioning schemes, as well as for exhibition stands.

The next phase of TEXO® evolution will increase its environmental credentials with the addition of thin film photovoltaic fabric from Flexcell providing options for integrating solar power generation into cladding of facades and roofs. Testing of very large lightweight arrays is underway and the results are very positive.

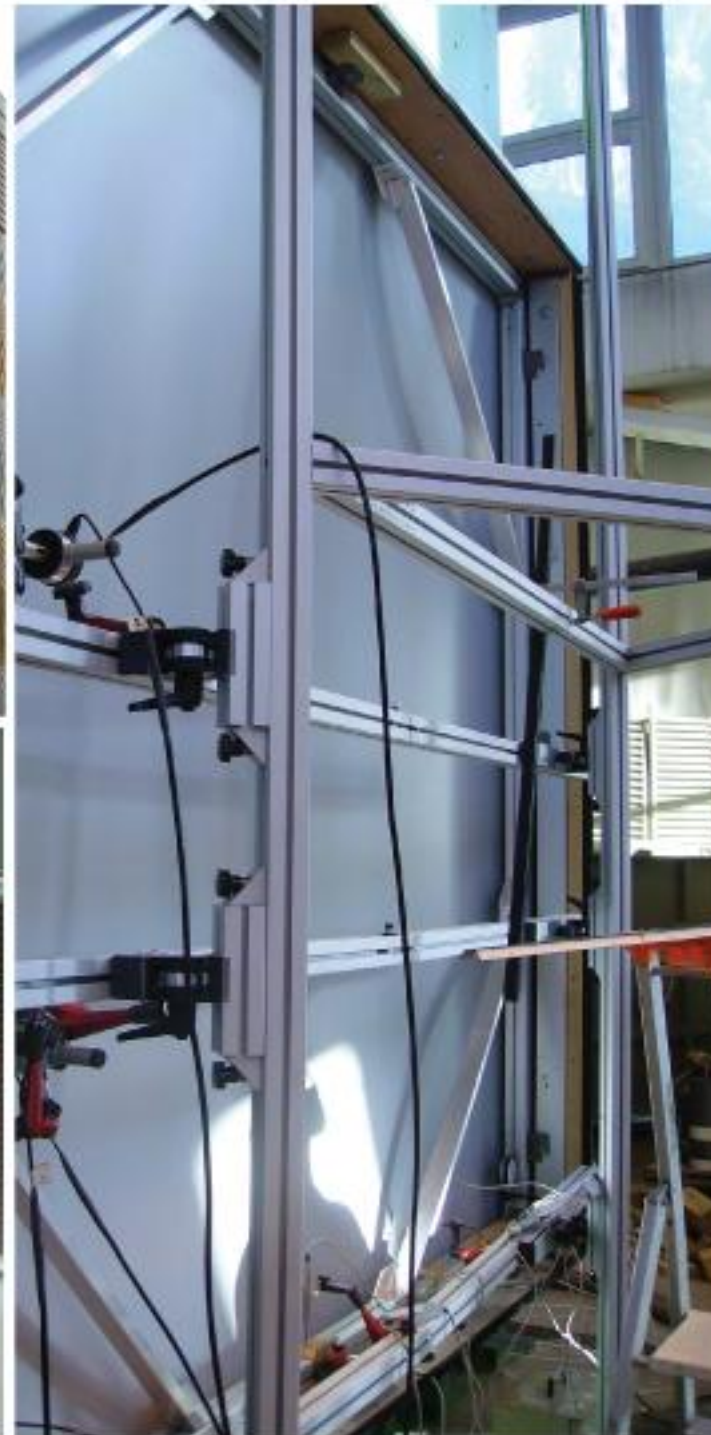
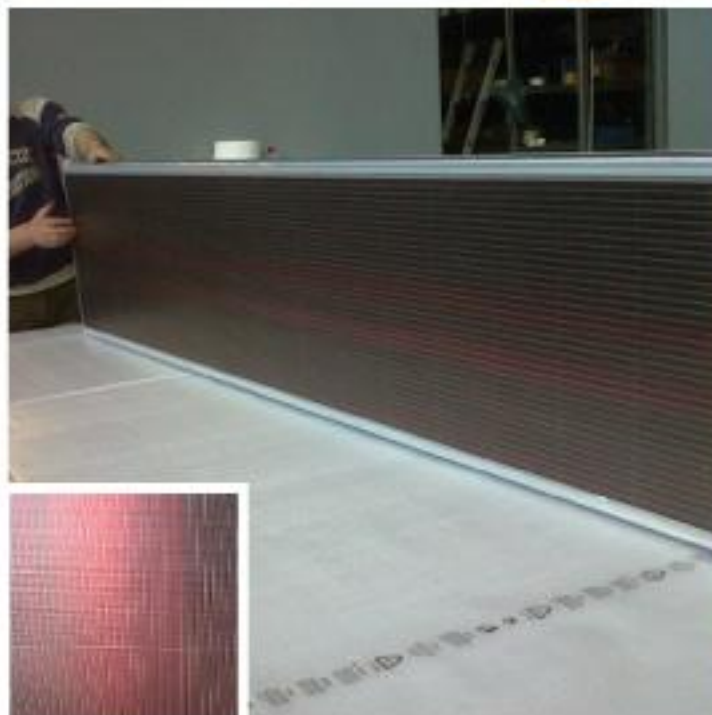

Wind Tunnel Testing at CSTB Paris

Confidence

TEXO® is already certified as 'external wall textile façade cladding panels' by CSTB of Paris and over 50,000m² of TEXO® has been installed to date.

www.tensoformasrl.com
www.basestructures.com

Base Structures Ltd is a delivery partner for TEXO®